



Tractors

ARION

640 C 630 C 620 C

CLAAS



Built to handle anything.

ARION 640 C / 630 C / 620 C

Meet the ARION 600 C – one of the most versatile tractors in the 140 to 170 hp class. Powerful, manoeuvrable and economical, the ARION 600 C has everything you could wish for from a machine that can tackle any task with confidence.



How are CLAAS tractors made? This website takes you on a journey through the world of tractor production at CLAAS.



tractors-making-of.claas.com

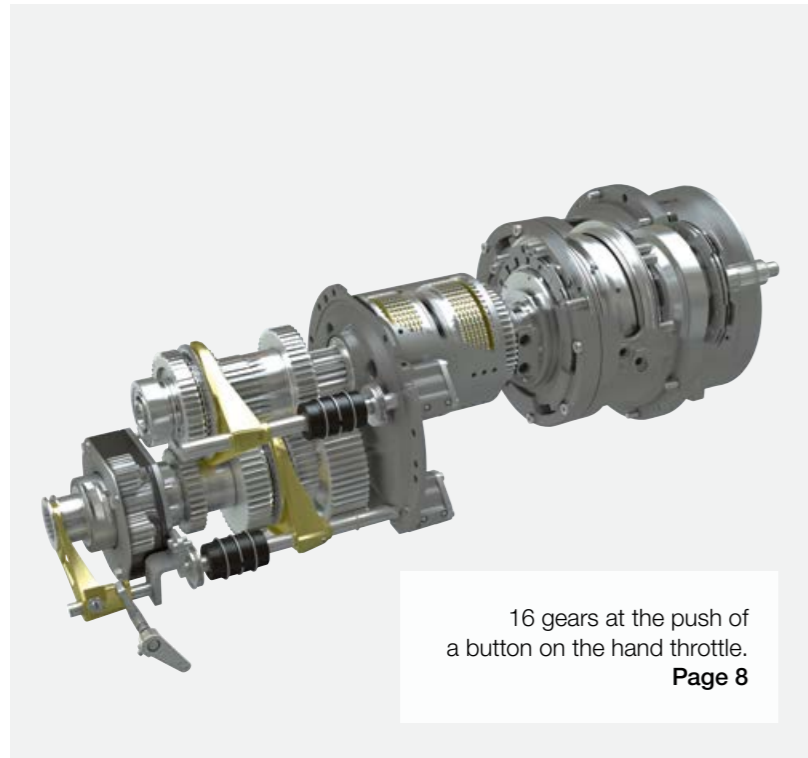

16 gears at the push of a button on the hand throttle.
Page 8

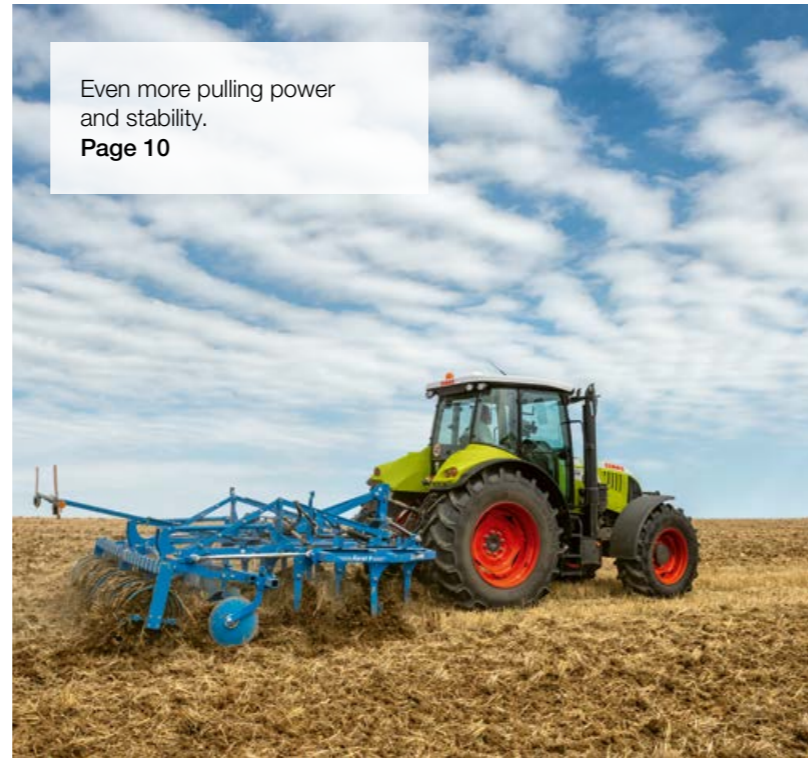

Even more pulling power and stability.
Page 10



Powerful lifting capacity at front and rear.
Page 12



Comfortable drive and intuitive controls.
Page 14



Save time and fuel with intelligent assistance.
Page 18



Easy maintenance and reliable service.
Page 20

CLAAS POWER SYSTEMS	6
Engine and transmission	8
Construction	10
Rear linkage, front linkage, front loader	12
Comfort	14
Cab	16
Operator assistance systems	18
Maintenance, CLAAS Service & Parts	20
Features	22
Specifications	23

Want to know more?
The QR codes will take you to our informative online offerings.

CLAAS POWER SYSTEMS (CPS) for intelligent drives.



Our drive system: the perfect interplay between optimal components.

Your CLAAS machine is much more than the sum of its individual parts. Top performance is only possible when all the parts are ideally matched and work together optimally.

In CLAAS POWER SYSTEMS (CPS), we have brought together top-quality components to create an intelligent drive system that sets new standards. Full engine output only when you need it. Drives that are suited to the way your machines are used. Fuel-saving technology which quickly pays off.

CPS | CLAAS
POWER
SYSTEMS



Engine and transmission.

- 6.8-l-6-cylinder from 145 to 165 hp (ECE R 120): strong pulling power even at low speeds
- Electronic common rail injection system: the right amount of diesel at the right time
- QUADRISHIFT transmission with four powershift speeds: the right gear for every situation
- REVERSHIFT electrohydraulic clutchless reverser: for easy, rapid turning manoeuvres
- 24-gear creep gear from 460 m/h: especially useful for horticultural work

- 1 Creep gears
- 2 Four hydraulically controlled ranges
- 3 REVERSHIFT clutchless reverser
- 4 QUADRISHIFT: four powershift speeds

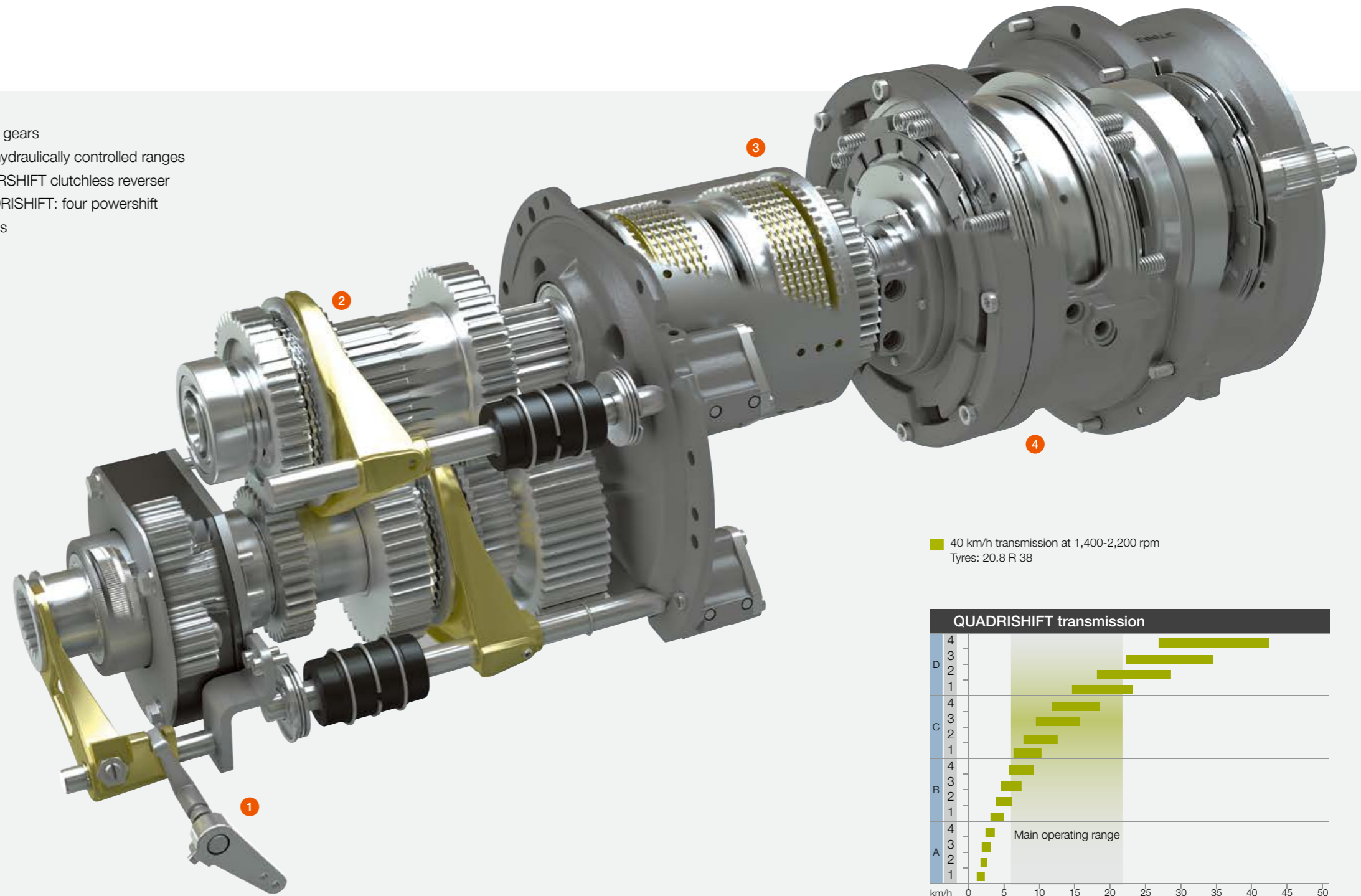

40 km/h transmission at 1,400-2,200 rpm
Tyres: 20.8 R 38

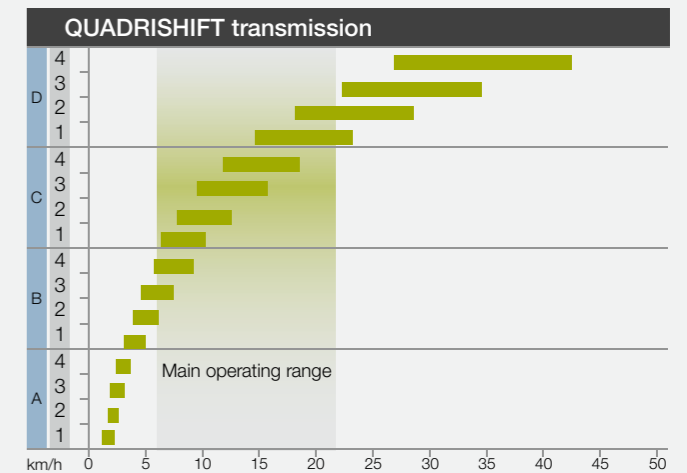

Four hydraulically controlled ranges.

You don't need a shift lever or clutch pedal to operate the ARION 600 C. Just touch the buttons on the hand throttle with your fingertips to shift effortlessly through all four powershift speeds and ranges.

Our engineers are continuously developing solutions to help make your work even more efficient, reliable and cost-effective than before. State-of-the art 6.8-l-6 cylinder engines with turbocharger provide the ARION 600 C with impressive torque and enormous torque increase.



Four powershift speeds save you having to shift between ranges in many cases.



Operate the REVERSHIFT clutchless reverser with your fingertips.

Designed for long, hard days.

Uniform weight distribution for maximum tractive power and stability.

You need a reliable tractor on your farm that can pull anything and remain stable. Two factors are crucial to this: the wheelbase and the weight distribution. The ARION 600 C features a long wheelbase of 2.82 m and almost equal weight distribution, with 53% at the front and 47% at the rear. This delivers the impressive tractive power and stability that make the ARION range so popular.

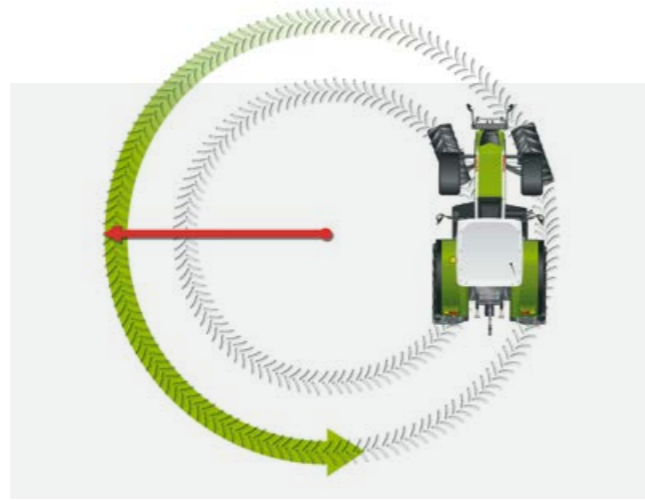

The tight turning radius saves valuable centimetres and precious time.



Short overall length ensures excellent manoeuvrability.

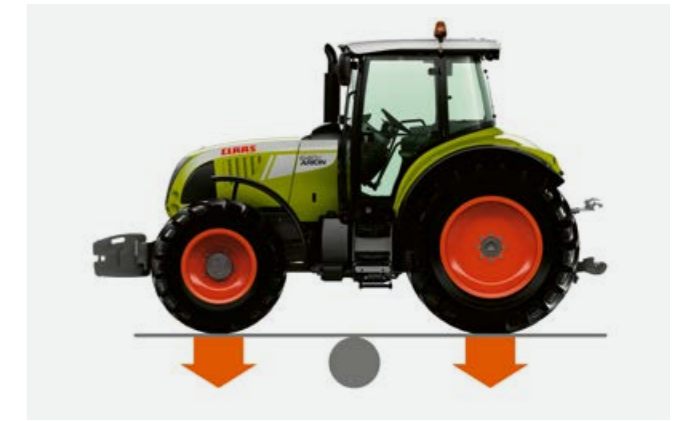

Intelligent weight distribution guarantees stability and tractive power.



Construction.

- Turning radius of just 4.85 m: steering lock up to 55° for outstanding manoeuvrability
- Overall length of just 4.72 m: good visibility and short trailer combination on the road
- Intelligent weight distribution of 53% at the front and 47% at the rear: excellent stability with attached implements
- Long wheelbase of 2.82 m: unrivalled driving comfort and safe road handling





Powerful hydraulics with two circuits.

When you need to get the job done, you can rely on the ARION 600 C. The hydraulics system has two selectable circuits and up to three auxiliary spool valves. The wide range of hitching options – for example a swinging drawbar or Piton Fix – offers great flexibility.

The rear linkage can handle max. 6.9 t at the ball ends and is digitally controlled. The 98-l hydraulic pump enables you to use a hydraulic spool valve and the rear linkage at the same time. So you can equip your ARION 600 with various implement combinations to increase your work rate and significantly reduce working hours and costs.



The front linkage is fully integrated and equipped with folding lift arms. With reduced spacing between the ball ends and front axle, it is ideal for any task requiring precision ground tracking. In combination with the front PTO shaft, the front linkage offers exceptional versatility.

Front and rear linkage.

- 6.9 t lifting capacity at the rear: the ARION can easily handle your large implements and seed drills
- TCE 15 T electronic rear linkage control: precision for optimum comfort and high-quality work
- 98 l/min hydraulic output at the rear: to suit your high-performance attached implements and equipment combinations
- 540 / 1,000 / ECO (optional) PTO: allows you to cut diesel consumption and noise levels at reduced engine speed
- Spool valve blocks are easily accessible for quick connection and disconnection
- 3.8 t lifting capacity at the front: enough power for implements and ballasting
- 1,000 front PTO: extends your range of applications and saves time and costs

Discover how CLAAS front loaders significantly increase the scope and versatility of your tractor.

With a choice of over 18 models in three series, you'll be ideally equipped whatever the job.



frontloader.claas.com

Precise, positive controls.

Our engineers design our tractors based on one simple premise: the machine should adapt to the user, and not the other way round. The driver shouldn't have to read a huge user manual before operating the tractor. Good tractors can be operated simply and easily.





Everything in full view.

- 1 Multifunction control lever to operate hand throttle and transmission
- 2 Two or three mechanical spool valves
- 3 Rear linkage: vibration damping, lift-height limiter, drop rate, draught and position control
- 4 Rear linkage: lower, raise, quick implement entry
- 5 Rear linkage: set the working depth
- 6 +/- buttons to operate the transmission are duplicated on the B-pillar
- 7 Activate four-wheel drive and differential lock
- 8 Activate rear PTO



Work in comfort on hot summer days.

The controls for the efficient air-conditioning system are in easy reach to the left of the instrument panel. The fan has four speed settings so you can adjust it to suit the conditions. The cooler compartment can hold a 1.5 l bottle.



Four-way suspension.

Four suspension points mean that the cab is fully isolated from the chassis. Longitudinal and lateral struts join the suspension points and keep the cab stable when turning corners or braking. Undistracted by jolts and bumps, the driver can focus fully on the job in hand.



Excellent view of the front loader.

The optional transparent roof gives you an unimpeded view of the working area during front loader work, allowing you to operate safely and with precision. For all other tasks, you can open the transparent roof outwards to let fresh air into the cab.



Vibration damping for a smoother ride.

Heavy implements mounted on the front and rear put a strain on you and your tractor. With the ARION 600 C both the front and rear linkage are equipped with vibration damping to compensate for peak loads during transport operations and when the attached implement is raised.



S10 (1): the smart all-rounder.

- High-resolution 10.4" touchscreen terminal
- Steering and ISOBUS functions
- Up to four cameras can be displayed

S7 (2): the compact steering specialist.

- High-resolution 7" touchscreen
- Steering functions

COMMUNICATOR (3): the rugged classic.

- 5.7" terminal
- ISOBUS functions

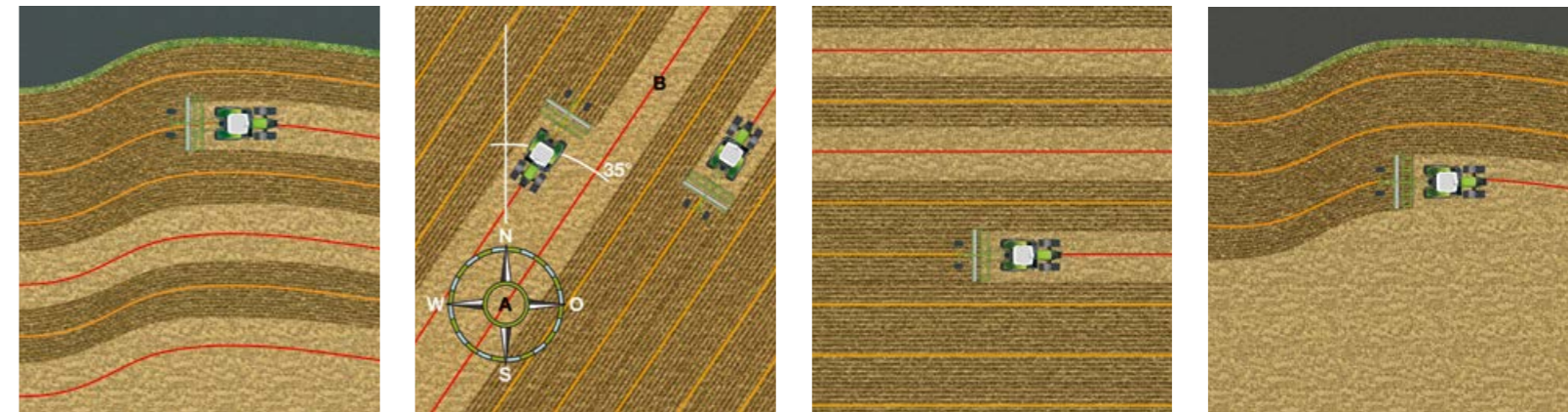

Three mobile terminals.

Thanks to ISOBUS-enabled terminals from CLAAS, you can control different ISOBUS implements from the comfort of your cab. There's no need to change the terminal when changing implement – it stays safely in the tractor cab and each implement is controlled via a dedicated screen on the monitor.

The three mobile terminals offered by CLAAS provide flexible solutions for your steering and ISOBUS systems. You can easily transfer the terminals from one machine to another depending on the season or the task. You can choose the factory-fitted or retrofitted system for your ARIO 600 C which best suits the needs of your farm.

Steering systems take the pressure off the driver.

Steering systems improve the quality of your work by automatically steering your tractor along the best possible path. This helps to eliminate errors and overlapping and allows you to make savings on diesel fuel, machine costs, fertiliser and crop protection products.

Discover many good reasons to invest in GPS steering systems here. For example, greater precision can cut your overall costs per hectare by 5%.



steeringsystems.claas.com

All set for speedy maintenance.

Good accessibility.

Daily maintenance work should be as straightforward as possible – because we know from experience that nobody enjoys doing things that are complicated or inconvenient. With the ARION 600 C, you can access all the relevant areas in no time at all. Engine, air filter, radiator and cab filter are easy to reach. What's more, the ARION 600 C can be refuelled just like a passenger car, and the tank holds a generous 280 litres of fuel.



The radiator can be quickly tilted to one side for cleaning.



Regular maintenance saves costs.

- The bonnet can be opened in a few simple steps, giving you easy access to all maintenance points
- Tool-free daily maintenance: perform simple maintenance tasks effortlessly yourself
- Engine oil change every 500 hours, transmission and hydraulic oil change every 1,500 hours: long maintenance intervals allow you greater operational flexibility
- PowerCore air filter with coarse dirt particle extraction: save valuable maintenance time during filter cleaning



It's easy to check the transmission oil level at the rear.



The generously sized air filter is designed for a long service life.



24-hour CLAAS Service & Parts. Discover how you can increase your machine reliability and minimise your risk of breakdowns with CLAAS ORIGINAL parts and MAXI CARE services.



service.claas.com

Good reasons to help you decide.



Unrivalled power.

- DPS-6.8-I-6 cylinder engines with common rail injection system
- Max. output 145–165 hp to ECE R 120
- QUADRISHIFT transmission with four powershift speeds
- 24-gear creep gear with speeds from 460 m/h
- Three mechanical spool valves
- Open-centre hydraulic circuit with 60 or 98 l/min output
- PTO speeds 540, 1,000 und ECO (optional)
- FIRST CLAAS SERVICE

Unrivalled convenience.

- CLAAS comfort concept with 4-point cab suspension
- High-comfort, air-conditioned cab
- Long wheelbase for intelligent weight distribution and enhanced driving comfort
- Clutchless shifting with +/- and shift buttons on the hand throttle
- TCE 15 T rear linkage control system
- Up to ten work lights for large-area lighting

The ARION 600 C is designed to meet your needs. Please contact us if you have any questions about purchasing, service and support. Our team is here to help.



contact.claas.com

ARION		640 C	630 C	620 C
Dimensions				
Height				
Rear wheels		20.8 R 38	20.8 R 38	20.8 R 38
Front wheels		16.9 R 28	16.9 R 28	16.9 R 28
Centre rear axle – cab upper edge (a)	mm	2110	2110	2110
Overall height (b)	mm	3055	3055	3055
Length				
Wheelbase (c)	mm	2820	2820	2820
Length (with front weight carrier and trailer hitch) (d)	mm	4728	4728	4728
Ground clearance				
Front axle (e)	mm	464	464	464
Rear axle (f)	mm	539	539	539
Weight				
(Standard tyres, with oil and fuel, fixed front axle, with driver)				
Rear wheels		18.4 R 38	18.4 R 38	18.4 R 38
Front wheels		14.9 R 28	14.9 R 28	14.9 R 28
Weight without ballast	kg	5930	5870	5600
Max. front ballast without front linkage	kg	700	700	700
Weight distribution with 700 kg front weight (rear/front)	%	53/47	53/47	53/47
Permissible gross weight (40 km/h version)	kg	9250	9250	9250
Tyres				
Rear tyres	Front tyres			
18.4 R 38 (460/85 R 38)	14.9 R 28 (380/85 R 28)	<input type="checkbox"/>	<input type="checkbox"/>	<input type="checkbox"/>
520/70 R 38	420/70 R 28	<input type="checkbox"/>	<input type="checkbox"/>	<input type="checkbox"/>
600/65 R 38	480/65 R 28	<input type="checkbox"/>	<input type="checkbox"/>	<input type="checkbox"/>
650/60 R 38 ¹	520/60 R 28 ¹	<input type="checkbox"/>	<input type="checkbox"/>	<input type="checkbox"/>
20.8 R 38 (520/85 R 38)	16.9 R 28 (420/85 R 28)	<input type="checkbox"/>	<input type="checkbox"/>	<input type="checkbox"/>
580/70 R 38	480/70 R 28	<input type="checkbox"/>	<input type="checkbox"/>	<input type="checkbox"/>
650/65 R 38	540/65 R 28	<input type="checkbox"/>	<input type="checkbox"/>	<input type="checkbox"/>

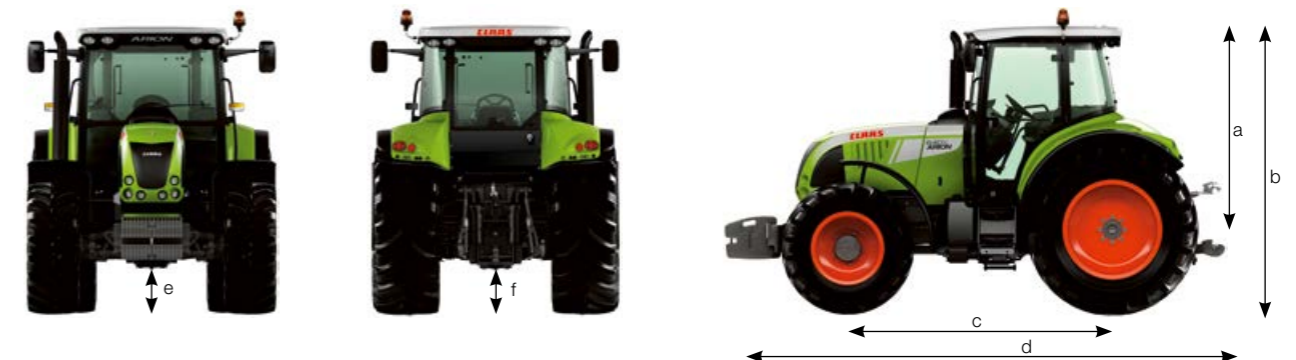

¹ XeoBib.

● standard ○ optional □ available – not available

ARION		640 C	630 C	620 C
Engine				
Manufacturer		DPS	DPS	DPS
Number of cylinders / intake		6/TI	6/TI	6/TI
Cubic capacity	cm ³	6788	6788	6788
Nominal engine speed	rpm	2200	2200	2200
Output at nominal engine speed (97/68/EC ¹)	kW	116	113	103
Output at nominal engine speed (ECE R 120 ²)	kW/hp	114/155	107/145	99/135
Max. output (ECE R 120 ²)	kW/hp	121/165	114/155	103/140
Output at nominal engine speed (ECE R 24)	kW/hp	110/150	103/140	96/130
Max. output (ECE R 24)	kW/hp	118/160	110/150	99/135
Max. output at engine speed	rpm	2000	2000	2000
Constant output	rpm	400	400	500
Engine speed at max. torque	rpm	1500	1500	1500
Max. torque (ECE R 120 ²)	Nm	667	633	580
Electronically controlled injection pump		●	●	●
Air filter dust aspiration		●	●	●
Fuel tank capacity	l	280	280	280
Oil-change interval	h	500	500	500

Transmission

Ratios F/R		16/16	16/16	16/16
Min. speed	km/h	1.8	1.8	1.8
Min. speed with creep gear	m/h	460	460	460
Max. speed	km/h	40	40	40
REVERSHIFT clutchless reverser		●	●	●
Powershift speeds		4	4	4
Electronically controlled ranges		4	4	4
Oil-change interval	h	1000	1000	1000

Rear axle

Electrohydraulically activated differential locks		●	●	●
Automatic differential lock		●	●	●
Max. rear tyres		650/65 R 38	650/65 R 38	650/65 R 38

PTO

Wet multi-disc clutch		●	●	●
Stop button for rear PTO on both mudguards		●	●	●
540/1000		●	●	●
540/540 ECO/1000/1000 ECO		○	○	○
Changeable PTO stub		●	●	●
Number of splines		6/8/21	6/8/21	6/8/21

ARION		640 C	630 C	620 C
Four-wheel drive front axle				
Electrohydraulic operation		●	●	●
Wet multi-disc clutch		●	●	●
Automatic 4-wheel drive		●	●	●
Max. steering angle	degrees	55	55	55
Castor angle	degrees	6	6	6
Angle of oscillation	degrees	10	10	10
Turning radius	m	4.85	4.85	4.85
Track	mm	1950	1950	1950
With tyres		14.9 R 28	14.9 R 28	14.9 R 28
Pivoting mudguards		○	○	○

Hydraulics

Open hydraulic circuit I		–	●	●
Flow at rated speed	l/min	–	60	60
Max. operating pressure	bar	–	200	200
Open hydraulic circuit II		●	○	○
Flow at rated speed	l/min	98	98	98
Max. operating pressure	bar	200	200	200
Number of spool valves (min./max.)		2 / 3	2 / 3	2 / 3
Flow control via the spool valve		●	●	●

Front linkage

Max. lifting power	t	3.80	3.80	3.80
Front PTO 1000 rpm		○	○	○

Rear linkage

Max. lifting capacity at ball ends	kg	6900	6900	6500
Continuous lifting power at ball ends	kg	4200	4200	4100
Vibration damping		●	●	●
Hydraulic trailer brakes		○	○	○
Air brakes		○	○	○
Trailer socket		●	●	●
25 amp socket		●	●	●

Cab

Unsprung		●	●	●
4-point suspension		○	○	○
Air conditioning		●	●	●
Cooler compartment		○	○	○

¹ Performance data fit criteria for admissibility. Performance as per 97/68/EC is identical to 2000/25/EC.

² Meets ISO TR 14396.

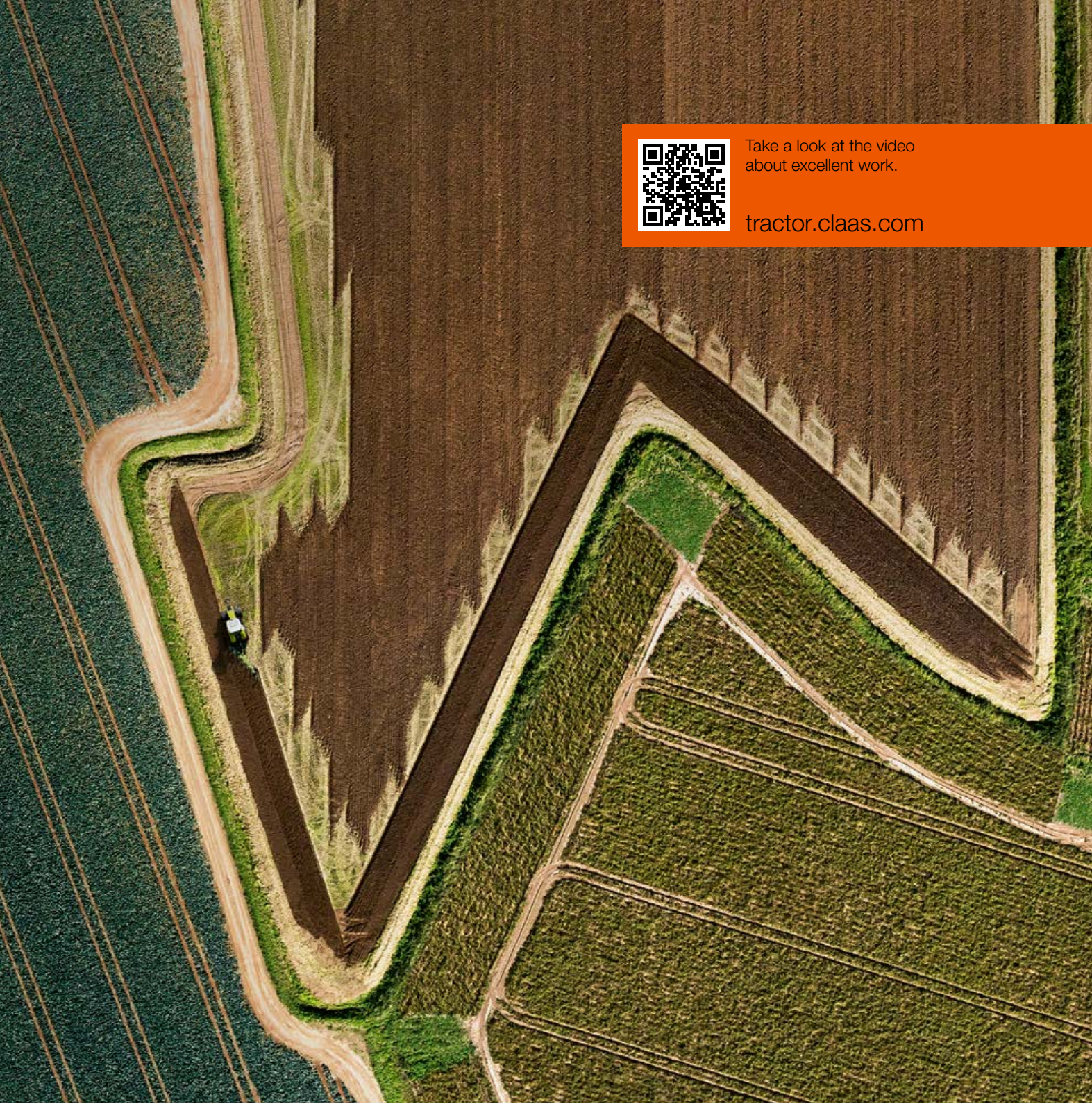

Take a look at the video
about excellent work.

tractor.claas.com

CLAAS KGaA mbH
Mühlenwinkel 1
33428 Harsewinkel
Deutschland
Tel. +49 5247 12-0
claas.com